

JOB NAME:

QUANTITY:

ITEM NO.:

PRODUCT NAME:

TWIST WASTE VALVE

_____ SPECIAL CONFIGURATION
(CHECK BASE MODEL AND OPTIONS)

MODEL:

24902 WITH FLAT STRAINER
& 14" X 18" OVERFLOW

OPTIONS OR MODIFICATIONS:

OTHER _____

FEATURES:

- * 3 1/2" SINK OPENING
- * 2" DRAIN OPENING
- * CAST BRONZE BODY AND WORKING PARTS
- * CHROME PLATED BODY AND WORKING PARTS
- * FLAT STRAINER
- * CSA CERTIFIED

DRAIN RATE:

- * 12 GPM

SHIPPING WEIGHT

- * 6.4 LBS

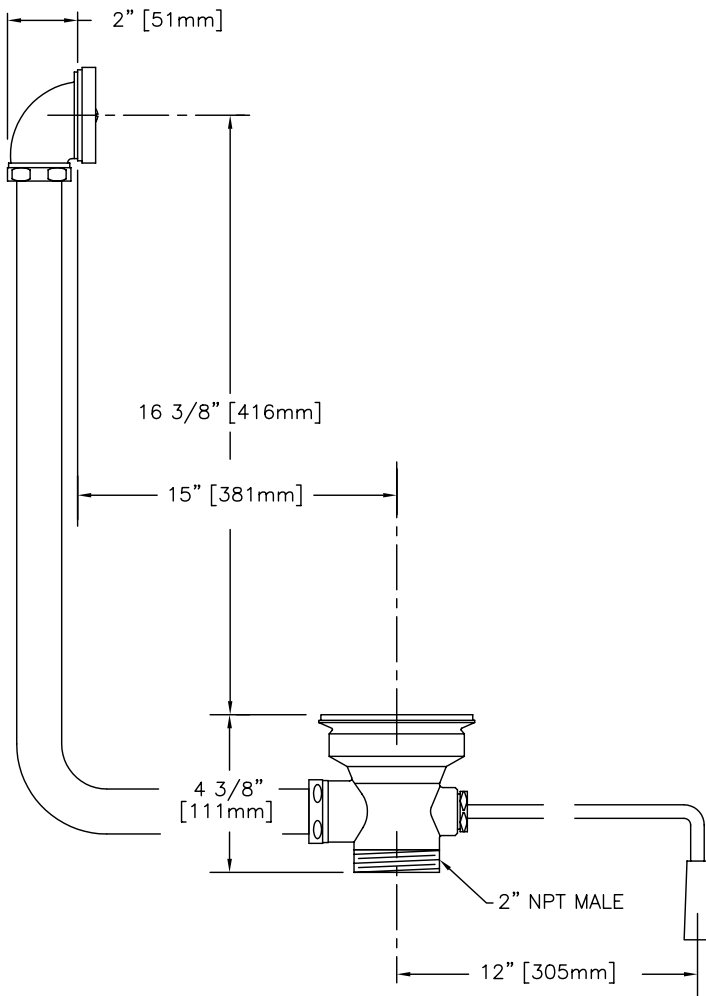

ROUGH-IN:

OVERFLOW:

DRAIN:

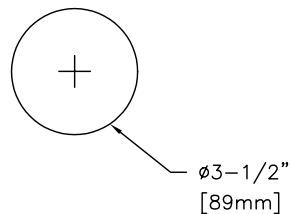
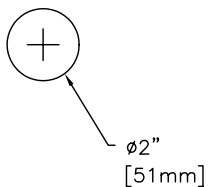

ANSI/A112.18.1M

Distributed by Fisher Manufacturing Company
P.O. Box 60 Tulare, CA 93725-0060
Phone 800-421-6162 FAX 800-8-FAUCET (800-832-8238)